

参考尺寸	( )
控制尺寸	[ ]
关键尺寸	

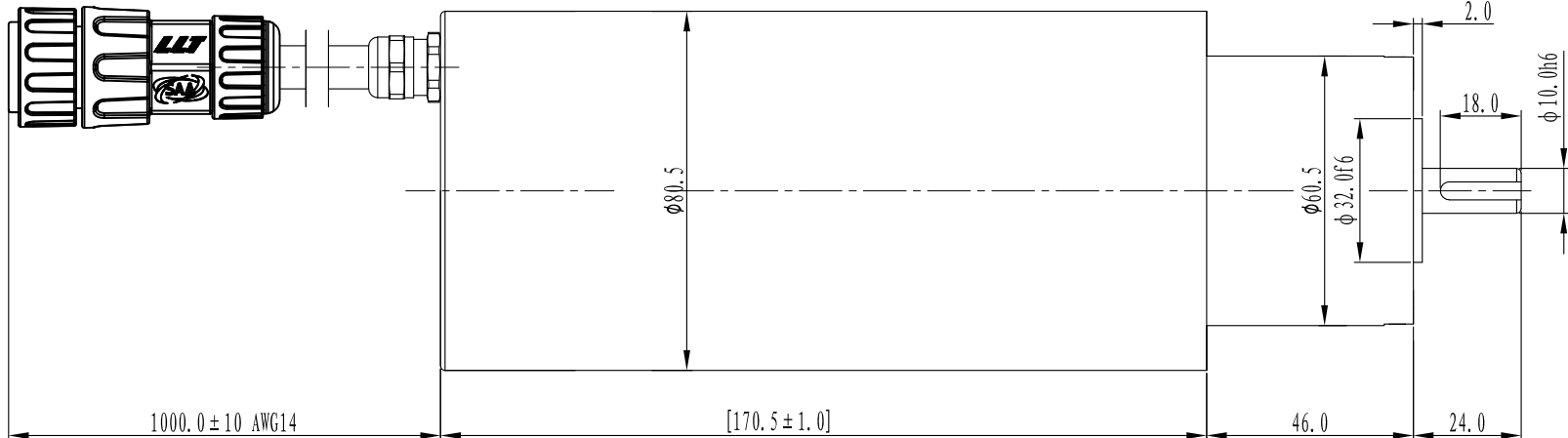
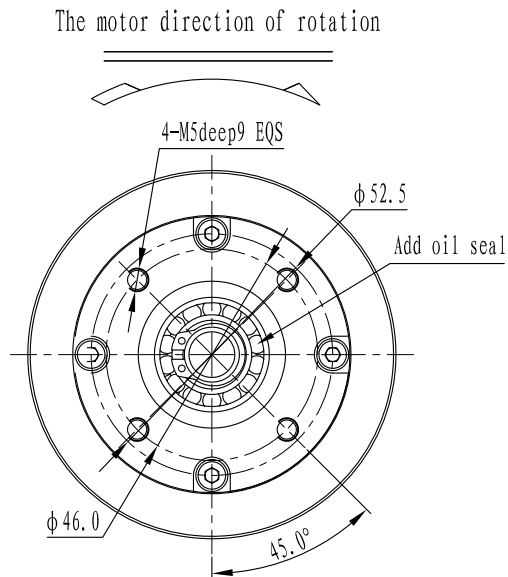

Technical Requirements:  
 1. There are no scratches on the surface of the motor.  
 2. The motor needs to be covered with a heat shrink sleeve

Motor type	ZYT08RC-GB	No-load speed	1500RPM±10%	Operating ambient temperature	-20° C+70° C	noise	65dB L100CM
Rated voltage	24VDC	Working system	S2	Reducer parameters		Gearbox structure	Integrated
Rated Power	150W	Insulation resistance	>20MΩ	Gearbox model	ZXJ60-20	Reducer gear ratio	Level 2
Rated current	<9.0A	life	2000H (Max)	Reduction ratio	20: 1	Gearbox and motor rotation direction	The same
Rated speed	1200RPM±8%	Electrical strength	750V/S	Transmission efficiency	81%	Maximum bearing torque of gearbox	20.0N.m
Rated torque	0.955N.m	Insulation level	B	Rated torque of the entire machine	15.47N.m	Motor wiring diagram 	
Machine no-load current	<0.9A	Protection level	IP65	Rated speed of the entire machine	60RPM±8%		

### Lead out function

Rough Red motor+  
 Thick black motor-  
 yellow-green grounding  
 Fine green hall A  
 Fine yellow hall B  
 Fine black hall GND  
 Fine red hall +5  
 Encoder 16 pulses

REV	WAS	DATE
-----	-----	------

X	± 0.15	APPD. BY	MATL.	见图样	TITLE. 外形图 (ZXJ60-20-1.0M-CF)
X.X	± 0.10				
X.XX	± 0.05	CHKD. BY	江苏欧邦电机制造有限公司	JIANG SU OUBANG PRECISION	MODEL. ZYT08RC-GB-24V-150W-1500R
ANGLE	± 1°				
TOLERANCE UNLESS SPECIFIED		DWN. BY	MOTOR CO. LTD		PART NO. WXT08-000
			SCALE. 1: 1		LPROJ: