

## 电机外形图 Motor outline drawing

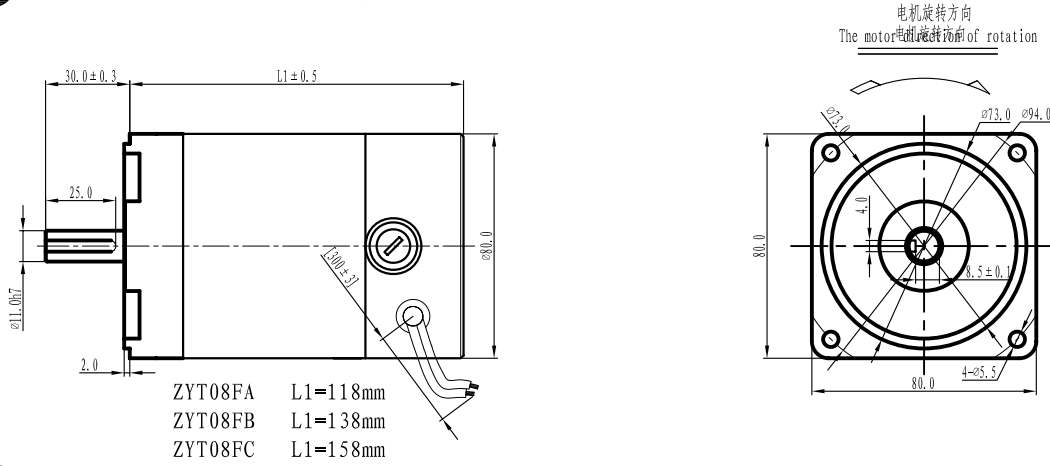

## 电机性能参数 Motor performance parameters

型号 Model	电压 Voltage (V)	输出功率 Output Power (W)	空载参数 No-load Parameters		负载参数 Load Parameters			电机寿命 Brush Life (H)	电机重量 Motor Weight (KG)
			转速 Speed (r/min)	电流 Current (A)	转速 Speed (r/min)	电流 Current (A)	力矩 Torque (N.m)		
ZYT08FA-24-1800	24	70	1800	0.4Max	1500	4.2	0.45	2000	1.87
ZYT08FA-24-3000	24	100	3000	0.7Max	2500	6	0.4	2000	1.87
ZYT08FA-12-1800	12	80	1800	0.8Max	1500	9.0	0.47	2000	1.87
ZYT08FA-12-3000	12	90	3000	1.4Max	2500	11	0.35	2000	1.87
ZYT08FB-24-1800	24	90	1800	0.4Max	1500	4.9	0.58	2000	2.26
ZYT08FB-24-3000	24	200	3000	0.8Max	2500	11.5	0.8	2000	2.26
ZYT08FB-12-1800	12	95	2000	0.9Max	1500	11.5	0.62	2000	2.26
ZYT08FB-12-3000	12	110	3000	1.5Max	2500	12.8	0.45	2000	2.26
ZYT08FC-24-1800	24	150	1800	0.55Max	1500	8.7	1.0	2000	2.82
ZYT08FC-24-3000	24	400	3000	1.0Max	2500	23.8	1.58	2000	2.82
ZYT08FC-12-1800	12	100	1800	1.0Max	1500	11	0.65	2000	2.82
ZYT08FC-12-3000	12	300	3000	2.0Max	2500	37	1.22	2000	2.82

可根据客户要求定做电机电压3V-220V电机, 电机转速1000-3000RPM

## 电机接线图 Wiring diagram of motor



## 电机出轴类型 Motor shaft type

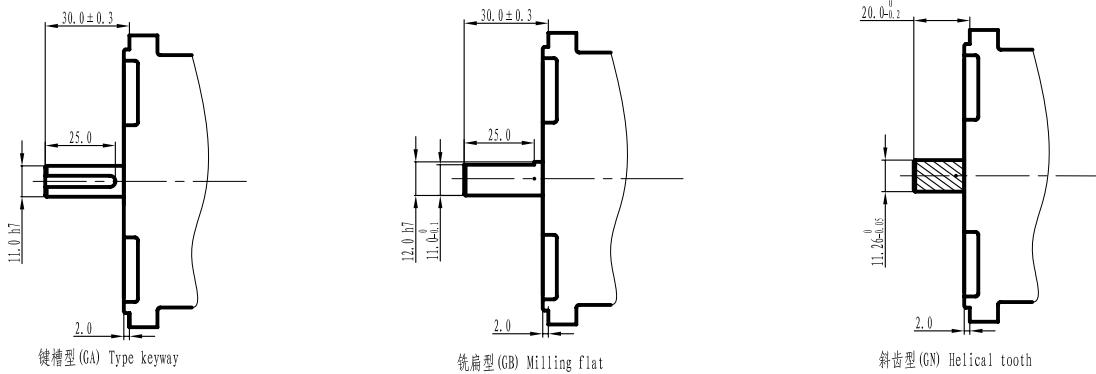

## 适配减速器 Adaptive speed reducer

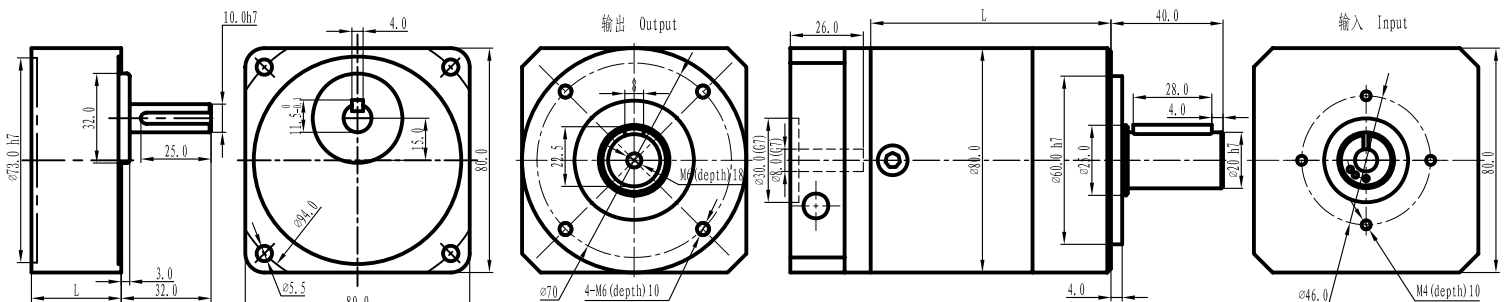

4GN3-15K L=32  
4GN18-180K L=43

精密行星减速器 Precision planetary reducer			
减速器长度 (L) Length (L) mm	减速比 Reduction ratio		
53	1:3.6	1:4.25	
61	1:13	1:15	1:18
72	1:47	1:55	1:65 1:76
84	1:168	1:198	1:234 1:276 1:326